

<b>Архангельск</b> (8182)63-90-72	<b>Ижевск</b> (3412)26-03-58	<b>Магнитогорск</b> (3519)55-03-13	<b>Пермь</b> (342)205-81-47	<b>Сургут</b> (3462)77-98-35
<b>Астана</b> (7172)727-132	<b>Иркутск</b> (395)279-98-46	<b>Москва</b> (495)268-04-70	<b>Ростов-на-Дону</b> (863)308-18-15	<b>Тверь</b> (4822)63-31-35
<b>Астрахань</b> (8512)99-46-04	<b>Казань</b> (843)206-01-48	<b>Мурманск</b> (8152)59-64-93	<b>Рязань</b> (4912)46-61-64	<b>Томск</b> (3822)98-41-53
<b>Барнаул</b> (3852)73-04-60	<b>Калининград</b> (4012)72-03-81	<b>Набережные Челны</b> (8552)20-53-41	<b>Самара</b> (846)206-03-16	<b>Тула</b> (4872)74-02-29
<b>Белгород</b> (4722)40-23-64	<b>Калуга</b> (4842)92-23-67	<b>Нижний Новгород</b> (831)429-08-12	<b>Санкт-Петербург</b> (812)309-46-40	<b>Тюмень</b> (3452)66-21-18
<b>Брянск</b> (4832)59-03-52	<b>Кемерово</b> (3842)65-04-62	<b>Новокузнецк</b> (3843)20-46-81	<b>Саратов</b> (845)249-38-78	<b>Ульяновск</b> (8422)24-23-59
<b>Владивосток</b> (423)249-28-31	<b>Киров</b> (8332)68-02-04	<b>Новосибирск</b> (383)227-86-73	<b>Севастополь</b> (8692)22-31-93	<b>Уфа</b> (347)229-48-12
<b>Волгоград</b> (844)278-03-48	<b>Краснодар</b> (861)203-40-90	<b>Омск</b> (3812)21-46-40	<b>Симферополь</b> (3652)67-13-56	<b>Хабаровск</b> (4212)92-98-04
<b>Вологда</b> (8172)26-41-59	<b>Красноярск</b> (391)204-63-61	<b>Орел</b> (4862)44-53-42	<b>Смоленск</b> (4812)29-41-54	<b>Челябинск</b> (351)202-03-61
<b>Воронеж</b> (473)204-51-73	<b>Курск</b> (4712)77-13-04	<b>Оренбург</b> (3532)37-68-04	<b>Сочи</b> (862)225-72-31	<b>Череповец</b> (8202)49-02-64
<b>Екатеринбург</b> (343)384-55-89	<b>Липецк</b> (4742)52-20-81	<b>Пенза</b> (8412)22-31-16	<b>Ставрополь</b> (8652)20-65-13	<b>Ярославль</b> (4852)69-52-93
<b>Иваново</b> (4932)77-34-06	<b>Киргизия</b> (ак)312-96-26-47	<b>Россия</b> (495)268-04-70	<b>Казахстан</b> (772)734-952-31	

[www.aeg.nt-rt.ru](http://www.aeg.nt-rt.ru) | | [age@nt-rt.ru](mailto:age@nt-rt.ru)

# Технические характеристики на промышленные выпрямители и зарядные устройства PROTECT RCS TPre TD бренда AEG Power Solutions

## PROTECT RCS TPR<sub>E</sub> TD

Thyristor controlled industrial  
rectifier & battery charger

Optimized for transmission  
& distribution applications



The Protect RCS TPR<sub>E</sub> TD battery charger system has been developed and designed to provide high reliability power supply and battery charging capability. The Protect RCS TPR<sub>E</sub> TD is a thyristor-controlled battery charger suitable for charging nickel-cadmium or lead-acid batteries while supplying DC loads. Its design is optimized for T&D (Transmission and Distribution) applications.

The rectifier is fitted inside a very compact cabinet and can be equipped with optional electrical and mechanical items in order to comply with most of the T&D specifications. It can also be connected to an inverter in order to deliver a safe AC supply.

The cabinets are floor mounted and can be customized to meet specific environmental requirements. The batteries are mounted in free-standing racks or cabinets.

### Typical applications

- Power generation
- Transmission & Distribution

## FEATURES

- Input isolation transformer, isolated DC output with built-in earth fault detection
- Standard system configurations
- Heavy industrial design
- Compact cabinet with natural cooling for most power ratings
- Built-in protection
- Customer cable connections on terminals
- Digital processing and setting of all parameters
- Monitoring of all parameters via the front panel display
- Built-in intelligent battery management system
- Temperature-compensated charge voltage regulation
- Manual or automatic high rate charge
- Parallel operation for redundancy and power increase
- Alarm and event logger, with a date and time-stamped event log memory
- Large communication facility options

## BENEFITS

- All chargers and options are identified with part numbers to permit reduced lead times
- Option list available for ratings in order to meet all T&D market specifications
- Compatible with common industrial battery types with easy parameter adjustment
- Field proven high reliability with microprocessor-controlled thyristor technology
- Ease of installation, start-up & maintenance, low Mean Time To Repair (MTTR)
- International service support

# PROTECT RCS TPRE TD

## STANDARD SYSTEM

The Protect RCS TPRE TD range of battery chargers has been preconfigured with some of the most commonly requested features built-in as standard. These systems are available “off-the-shelf” with standard drawings and user documentation.

### Standard configuration

- Single systems from 24 VDC to 220 VDC and 20 A to 150 A
- Internal rectifier input breaker Q1
- 6-pulse rectifier bridge with input isolation transformer
- Digital control card GCAU
- Output filter C1 ripple voltage <2% RMS without battery
- Rectifier F1 fuse and rectifier shunt R2
- DC output isolation switch
- Multi-functional LCD with 2 LEDs indicates the system status

- Output DC cable drop compensation
- Tropicalized control electronic boards
- Low smoke – halogen free wires and cables
- Common fault remote alarm
- Floor mounted cabinet with external IP41 protection and IP20 with open doors
- Cabinet color RAL 7032
- Power and control cable marking
- Door able to open to 180° with key lock
- Bottom cable entry
- Input/output load terminals X1 and X2
- Standard rating plate

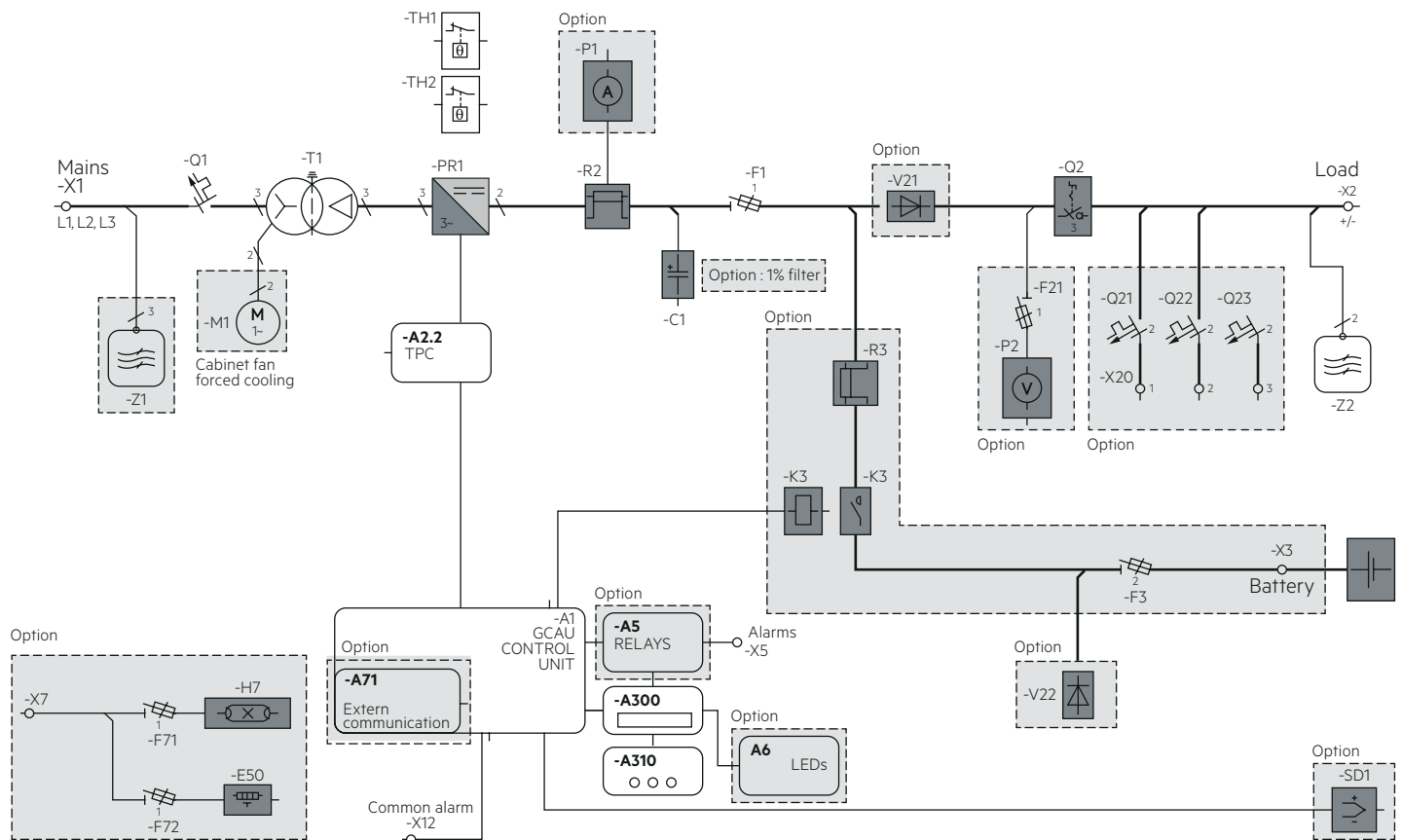



## OPTIONS

The standard system can be enhanced by additional options already integrated into standard drawing packages and user documentation.

All documentation is available for download on the AEG Power Solutions web site, download section.

To provide exact solutions for each application, we offer a wide range of options.

### System

- 3 x DC distribution breakers with spare capacity
- Blocking diode for paralleling
- 1% DC output filter for all
- 0.1% DC output filter for 48V rating
- Battery reverse polarity protection
- Battery output including battery shunt, protection by fuse and low voltage disconnect contactor
- Battery protection box including fuses and current measurement

### Alarms/signaling/measurement

- LED alarm indicators in front panel
- Relay cards (8 free contacts each)
- Additional analog meters
- Temperature charging compensation sensors & cables

### Communication

- RS485 Modbus RTU protocol
- TCP/IP interface for SMTP or Modbus
- Protocol converter IEC 61850
- Monitoring and management software

### Mechanical

- Interior cabinet light & cabinet heater
- Lifting eyes
- Hardcopies of drawings, operation manual and test report
- Cabinet with IP42 protection degree

# Specifications

<b>INPUT</b>	
Nominal input voltage	Three phase 400 V $\pm 10\%$ (+15% – 20% functional) 380 V and 415 V optional
Frequency	50/60 Hz, $\pm 6\%$
Power factor	0.8 (nominal power)
<b>OUTPUT</b>	
Voltage (UDC)	24, 36, 48, 60, 110, 127, 220 VDC
DC voltage settings range	Floating charge – 75% – 125% of UDC nominal at full load and nominal mains voltage ( $\pm 10\%$ ) High-rate charge – 75% – 135% of UDC nominal at full load and nominal mains voltage (0/+10%)
Static voltage regulation	$\pm 1\%$ at float voltage, 0 – 100% DC load variations, input nominal voltage $\pm 10\%$ , frequency $\pm 6\%$ , temp. range 0°C to +40°C
Dynamic voltage regulation	10 – 100%, 100% – 10% load step – deviation 8%
DC ripple voltage	2% rms typically of UDC nominal battery not connected
DC current	According to range
Current settings range	0 – 100%
DC current regulation	0/+2% of current limit
Long-term stability	0.15% per 1000 hrs
Temperature coefficient	<0.02% per °C
Charging characteristic	Constant current/constant voltage (I/U as per IEC 478) during float charge
Insulation resistance	>200 M $\Omega$ /500 VDC
Input/output isolation	2,500 VAC between input/output and electrical earth
<b>MECHANICAL</b>	
Degree of protection	IP41 according to IEC 60529
Equipment color	RAL 7032, powder coated, textured paint
Dimensions & weight	L x D x H = 600 x 600 x 1300 mm – weight according to range
Acoustic noise @ 1m	45 – 65 dB(A)
Connections	Bottom
<b>ENVIRONMENTAL</b>	
Type of cooling	Natural convection or fan forced cooling depending on output power
Operating temperature	0°C to +50°C
Storage temperature	-25°C to +70°C
Operating humidity	10% to 95% R H Non-Condensing
Installation height	0 to 1,000 m – de-rating @ 1% per 100 m above 1,000 m up to 3,000 m
Seismic	BELLCORE GR-63-CORE issue 1 for Zone 1
<b>STANDARDS</b>	
Safety	IEC/EN 60529, EN50178
EMC	IEC/EN 61000-6-2, IEC/EN 61000-6-4
Performance	IEC/EN 60146-1-1
Approvals & certification	CE marking

PROTECT RCS	TPRe TD						
	24	36	48	60	110	127	220
BATTERY VOLTAGE (VDC)							
Output current (A)	20 A (N)	20 A (N)	20 A (N)	20 A (N)	20 A (N)	20 A (N)	20 A (N)
Cabinet cooling	110 kg	110 kg	120 kg	120 kg	220 kg	220 kg	230 kg
- N = natural	25 A (N)	25 A (N)	25 A (N)	25 A (N)	25 A (N)	25 A (N)	25 A (N)
- F = forced	110 kg	110 kg	120 kg	120 kg	220 kg	220 kg	240 kg
Cabinet weight (kg)	40 A (N) 120 kg	40 A (N) 120 kg	40 A (N) 140 kg	40 A (N) 140 kg	40 A (N) 240 kg	40 A (N) 240 kg	40 A (F) 250 kg
	60 A (N) 140 kg	60 A (N) 140 kg	60 A (N) 160 kg	60 A (N) 160 kg	60 A (N) 260 kg	60 A (N) 260 kg	60 A (F) 270 kg
	100 A (N) 160 kg	100 A (N) 160 kg	100 A (N) 180 kg	100 A (N) 180 kg	100 A (F) 280 kg	100 A (F) 280 kg	
	125 A (N) 170 kg	125 A (N) 170 kg	125 A (N) 190 kg	125 A (N) 190 kg	125 A (F) 300 kg	125 A (F) 300 kg	
	150 A (N) 190 kg	150 A (N) 190 kg	150 A (F) 210 kg	150 A (F) 210 kg	150 A (F) 320 kg	150 A (F) 320 kg	

<b>Архангельск</b> (8182)63-90-72	<b>Ижевск</b> (3412)26-03-58	<b>Магнитогорск</b> (3519)55-03-13	<b>Пермь</b> (342)205-81-47	<b>Сургут</b> (3462)77-98-35
<b>Астана</b> (7172)727-132	<b>Иркутск</b> (395)279-98-46	<b>Москва</b> (495)268-04-70	<b>Ростов-на-Дону</b> (863)308-18-15	<b>Тверь</b> (4822)63-31-35
<b>Астрахань</b> (8512)99-46-04	<b>Казань</b> (843)206-01-48	<b>Мурманск</b> (8152)59-64-93	<b>Рязань</b> (4912)46-61-64	<b>Томск</b> (3822)98-41-53
<b>Барнаул</b> (3852)73-04-60	<b>Калининград</b> (4012)72-03-81	<b>Набережные Челны</b> (8552)20-53-41	<b>Самара</b> (846)206-03-16	<b>Тула</b> (4872)74-02-29
<b>Белгород</b> (4722)40-23-64	<b>Калуга</b> (4842)92-23-67	<b>Нижний Новгород</b> (831)429-08-12	<b>Санкт-Петербург</b> (812)309-46-40	<b>Тюмень</b> (3452)66-21-18
<b>Брянск</b> (4832)59-03-52	<b>Кемерово</b> (3842)65-04-62	<b>Новокузнецк</b> (3843)20-46-81	<b>Саратов</b> (845)249-38-78	<b>Ульяновск</b> (8422)24-23-59
<b>Владивосток</b> (423)249-28-31	<b>Киров</b> (8332)68-02-04	<b>Новосибирск</b> (383)227-86-73	<b>Севастополь</b> (8692)22-31-93	<b>Уфа</b> (347)229-48-12
<b>Волгоград</b> (844)278-03-48	<b>Краснодар</b> (861)203-40-90	<b>Омск</b> (3812)21-46-40	<b>Симферополь</b> (3652)67-13-56	<b>Хабаровск</b> (4212)92-98-04
<b>Вологда</b> (8172)26-41-59	<b>Красноярск</b> (391)204-63-61	<b>Орел</b> (4862)44-53-42	<b>Смоленск</b> (4812)29-41-54	<b>Челябинск</b> (351)202-03-61
<b>Воронеж</b> (473)204-51-73	<b>Курск</b> (4712)77-13-04	<b>Оренбург</b> (3532)37-68-04	<b>Сочи</b> (862)225-72-31	<b>Череповец</b> (8202)49-02-64
<b>Екатеринбург</b> (343)384-55-89	<b>Липецк</b> (4742)52-20-81	<b>Пенза</b> (8412)22-31-16	<b>Ставрополь</b> (8652)20-65-13	<b>Ярославль</b> (4852)69-52-93
<b>Иваново</b> (4932)77-34-06	<b>Киргизия</b> (ак)312-96-26-47	<b>Россия</b> (495)268-04-70	<b>Казахстан</b> (772)734-952-31	

[www.aeg.nt-rt.ru](http://www.aeg.nt-rt.ru) | | [age@nt-rt.ru](mailto:age@nt-rt.ru)